

C_243 Horizon Set

80 ml / h: 52 mm / Ø 60 mm

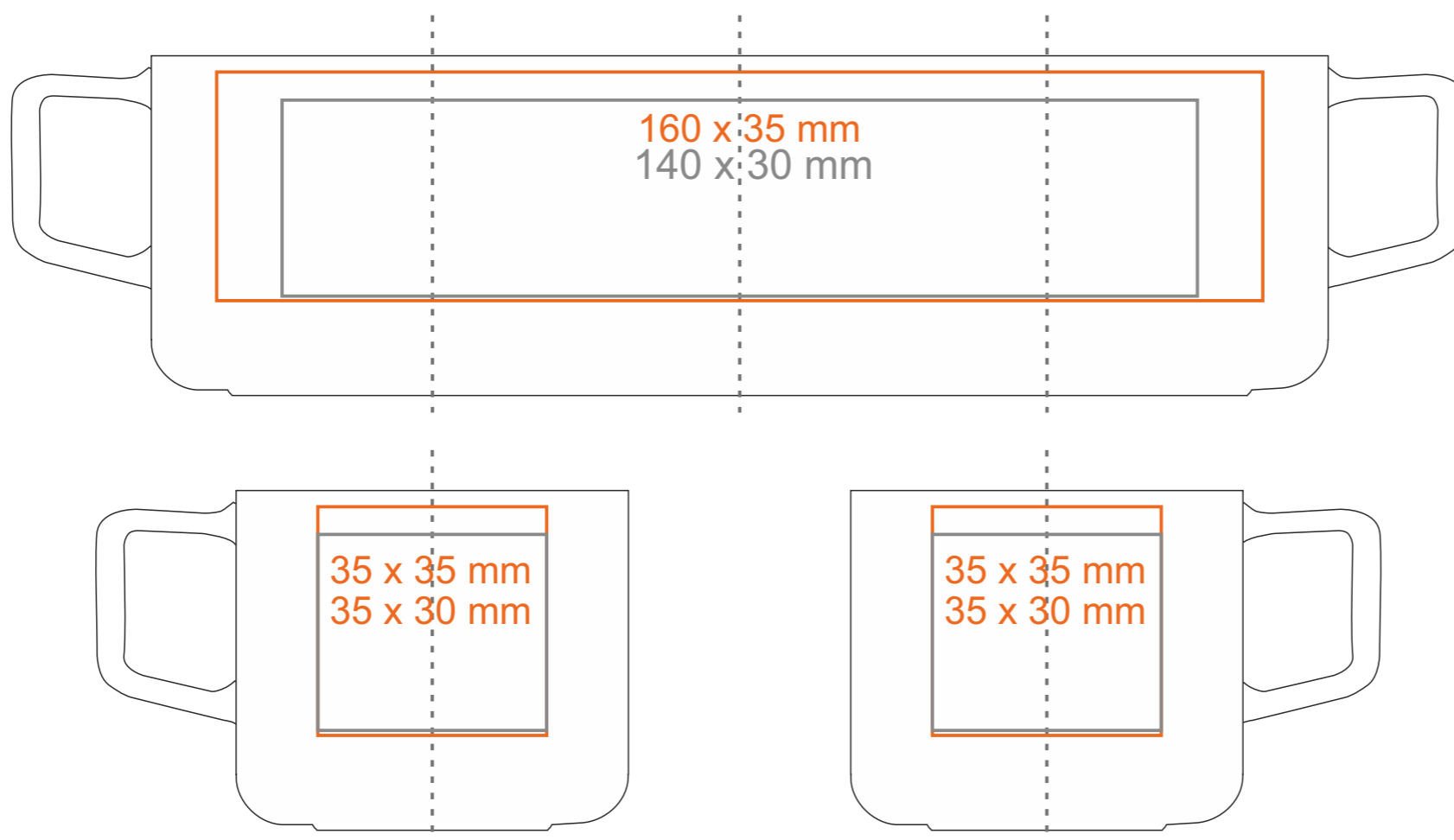

Spodek Ø 120 mm

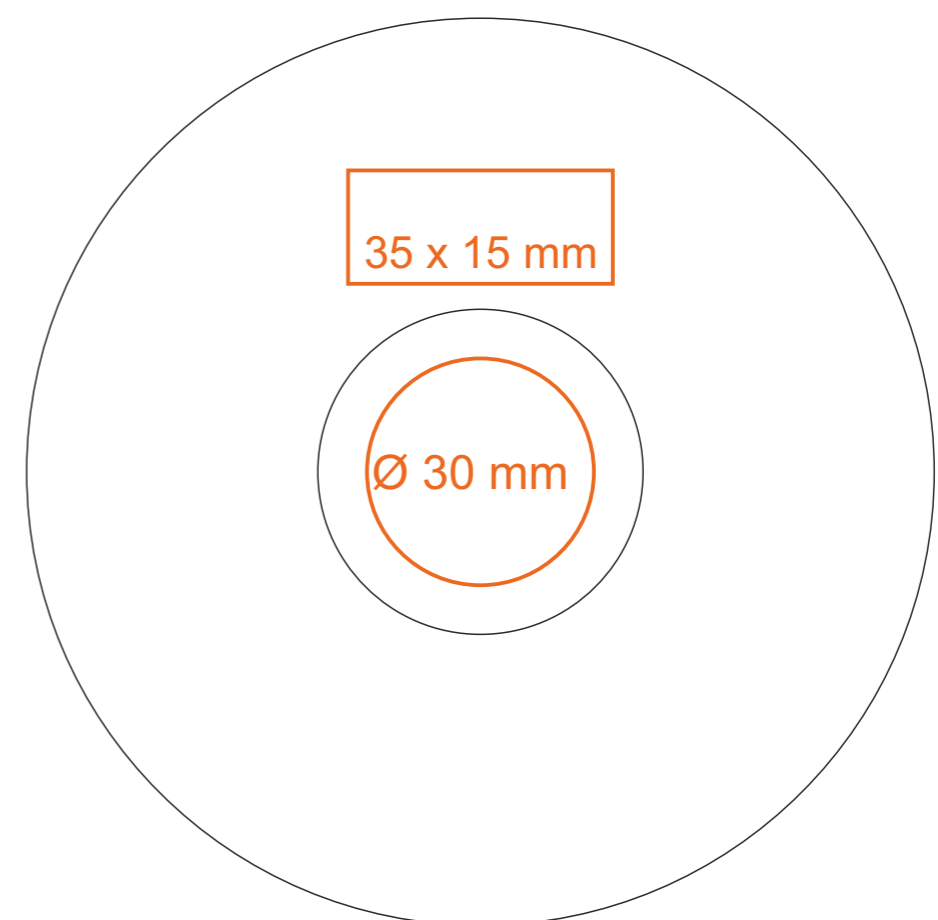

Stampa sul manico
Stampa interna
Stampa sul fondo esterno

- 15 x 9 mm
- 35 x 15 mm
- Ø 30 mm

*Nel caso di progetti per la stampa a transfer oltre l'area di stampa standard, si prega di contattare il nostro ufficio commerciale.

[Come preparare il materiale di stampa?](#)

significato

- Stampa a Transfer
- Sensitive Touch
- Stampa Diretta

C_243 Horizon Set

240 ml / h: 72 mm / Ø 83 mm

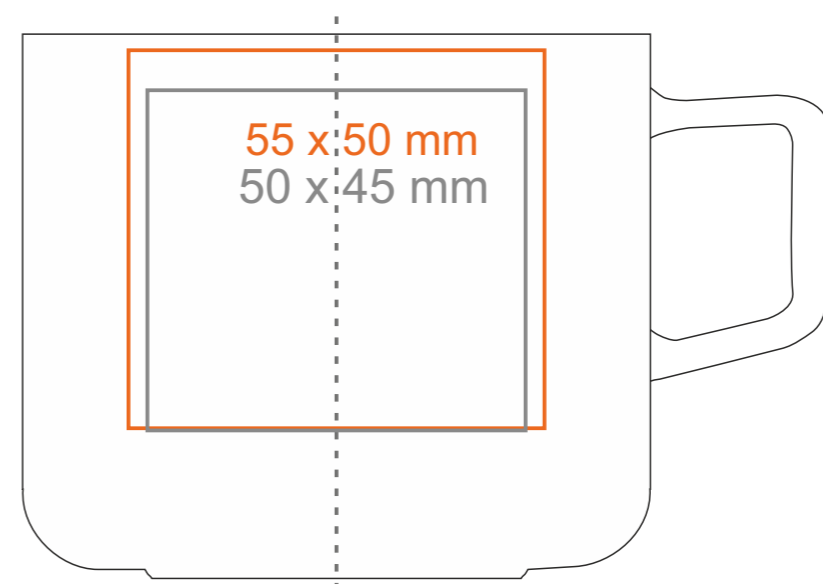
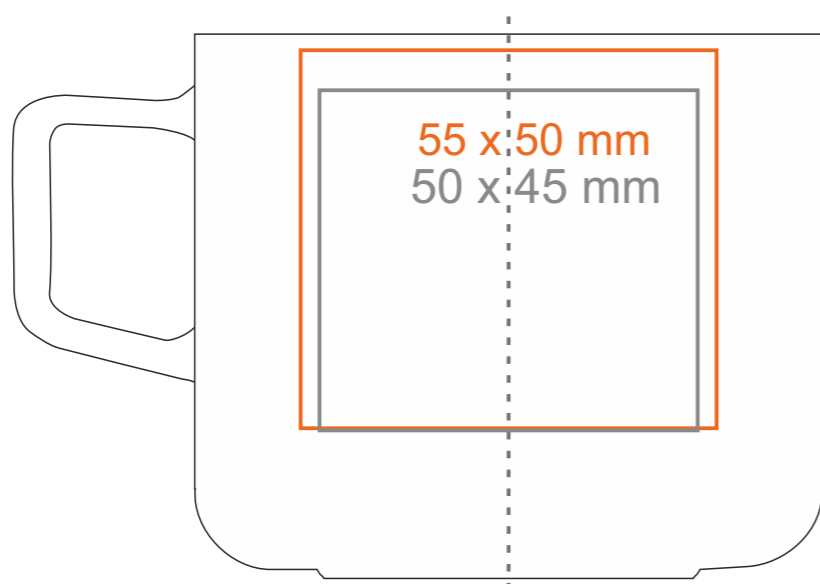
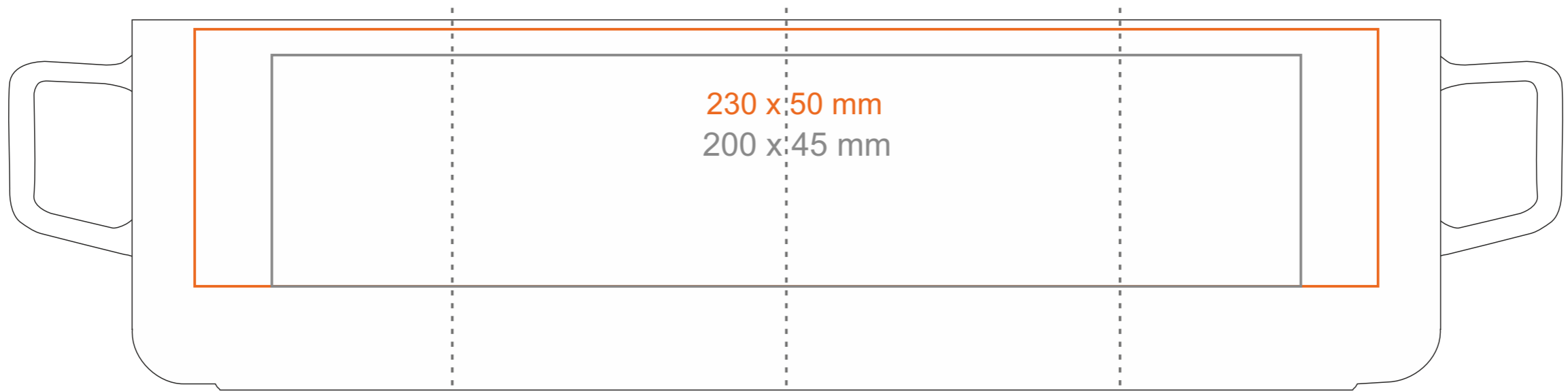

Spodek Ø 150 mm

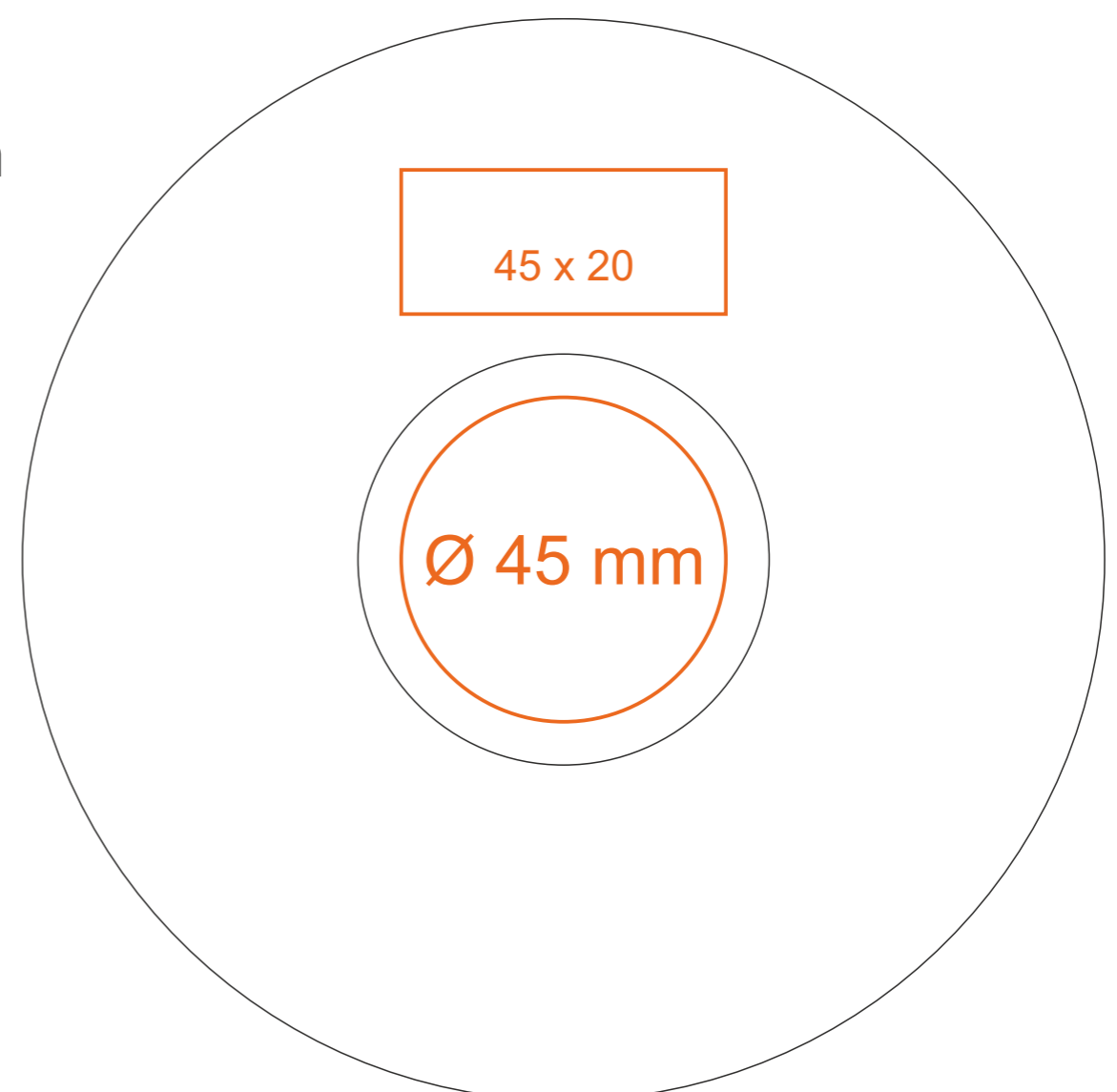



Stampa sul manico
Stampa interna
Stampa sul fondo interno
Stampa sul fondo esterno

- 20 x 10 mm
- 45 x 20 mm
- Ø 50 mm
- Ø 20 mm

*Nel caso di progetti per la stampa a transfer oltre l'area di stampa standard, si prega di contattare il nostro ufficio commerciale.

[Come preparare il materiale di stampa?](#)

significato

-  Stampa a Transfer
-  Sensitive Touch
-  Stampa Diretta

C_243 Horizon Set

280 ml / h: 62 mm / Ø 101 mm

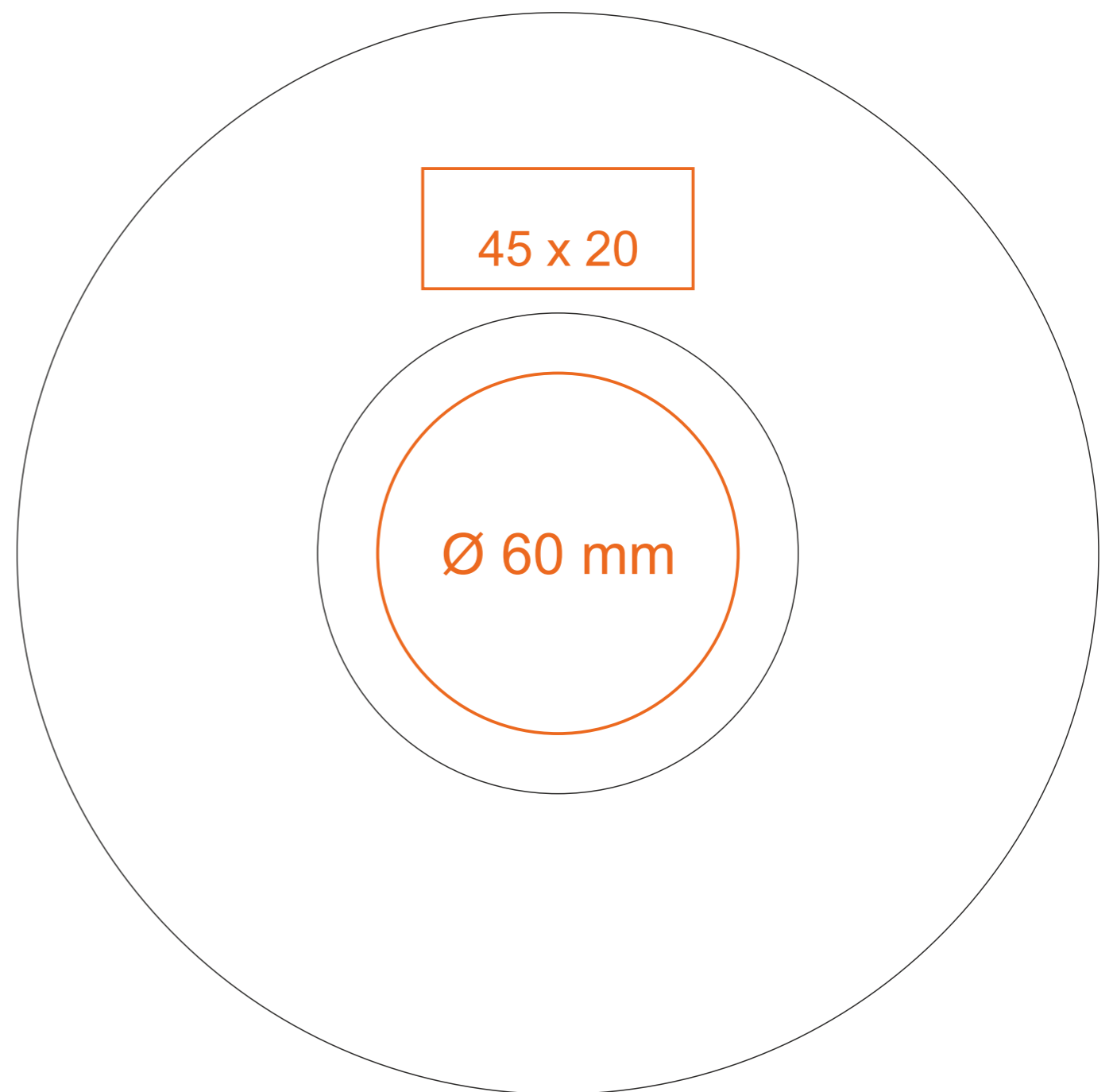
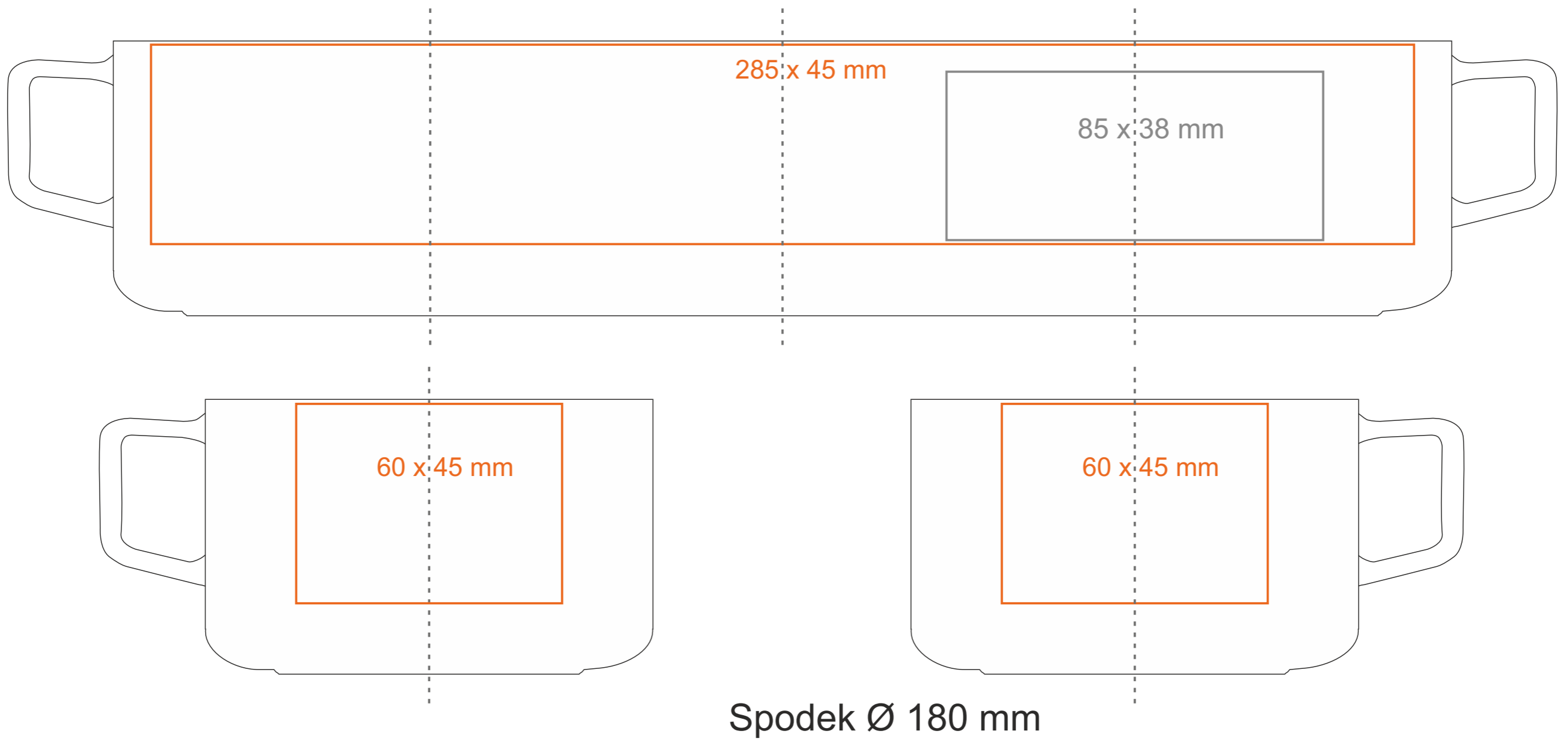

- Stampa sul manico
- Stampa interna
- Stampa sul fondo interno
- Stampa sul fondo esterno

- 20 x 10 mm
- 50 x 20 mm
- Ø 60 mm
- Ø 35 mm

*Nel caso di progetti per la stampa a transfer oltre l'area di stampa standard, si prega di contattare il nostro ufficio commerciale.

[Come preparare il materiale di stampa?](#)

significato

- Stampa a Transfer
- Sensitive Touch
- Stampa Diretta